

2.5MW Series Wind Turbine Generators

2.5MW 系列风力发电机组 >>>>



FEATURES 特点

1, Lightweight Design

Compact overall turbine design.

It is small, lightweight, and convenient to transport and hoist.

2, Higher Efficiency

It uses a permanent magnet synchronous generator to avoid excitation loss and achieve increased efficiency.

It provides a wide speed-adjustment range for superior performance in low-wind conditions

3, Higher Reliability

The gearbox-free design frees you of the worry of gearbox failure during the turbine's service life.

The generator adopts a single-bearing support design and a simple structure.

4, Lower O&M Costs

The product has a high generator protection grade and good environmental adaptability.

The low maintenance toothed belt pitch system design helps reduce the lubrication and maintenance costs of pitch control gears.

There is no generator slip ring or carbon

brush maintenance.

With the gearbox-free design, there is no need to inspect or replace gearbox oil.

5, Superior grid connection performance

It has strong low-voltage ride-through capabilities and possesses zero voltage ride-through capability.

The turbine comes with reactive power output, reducing the investment in centralized reactive power compensation.

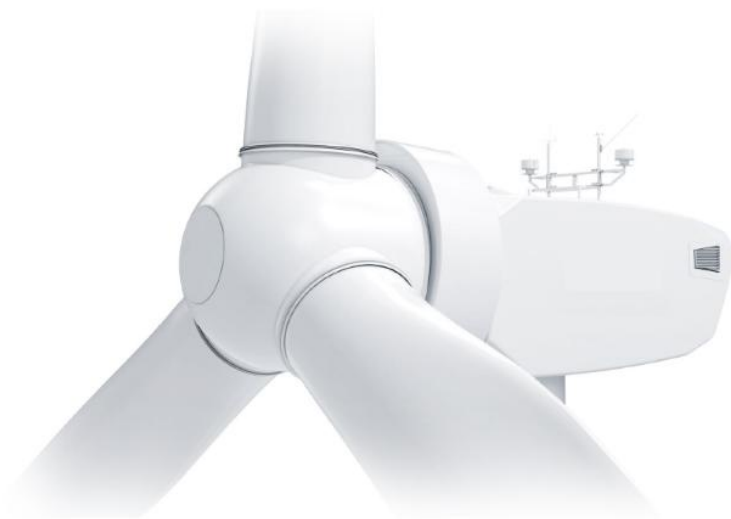
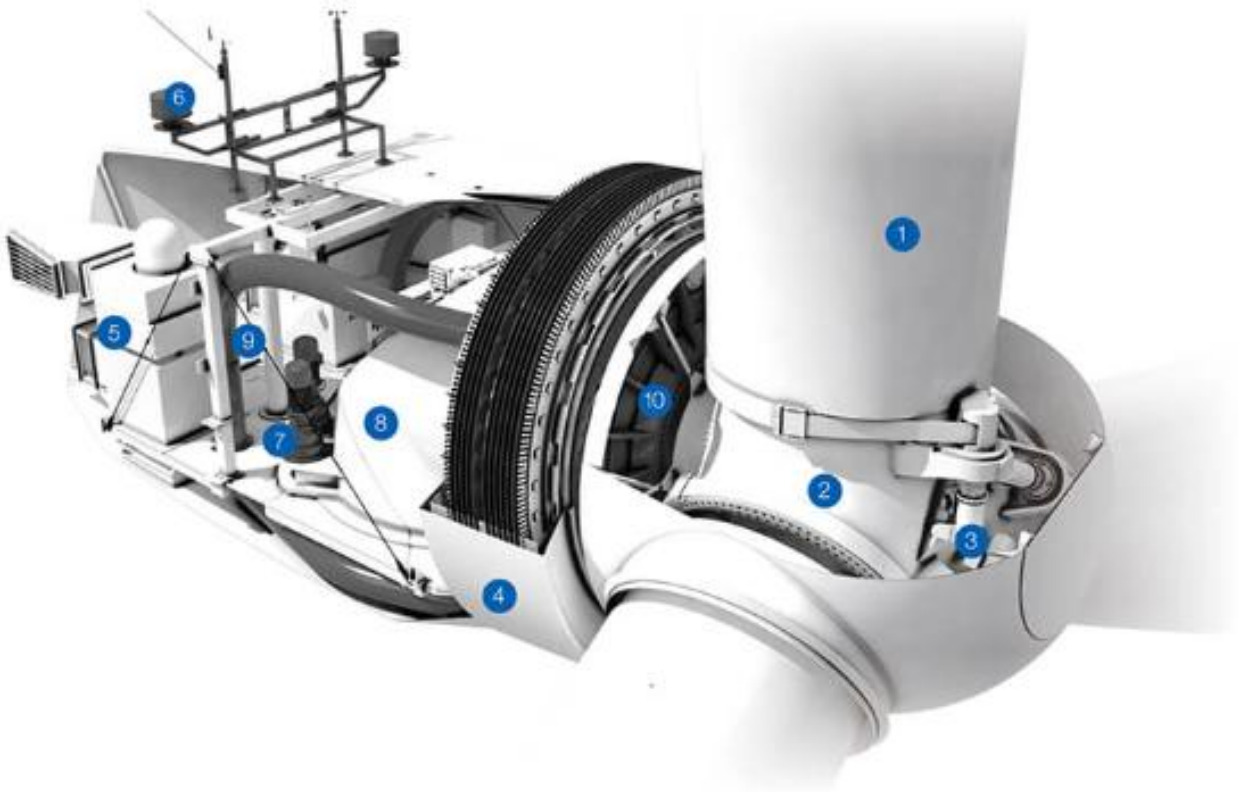

Turbine Structure

1. Blade
2. Hub
3. Pitch control system
4. Generator
5. Generator heat dissipation system (heat exchanger)
6. Wind measurement system
7. Yaw system
8. Base
9. Hoist
10. Main bearing